

Three-phase energy meter DSZ12D-3x80A  
with display and MID approval



**Only skilled electricians may install this electrical equipment otherwise there is the risk of fire or electric shock!**

Temperature at mounting location: -25°C up to +55°C.  
Storage temperature: -25°C up to +70°C.  
Relative humidity: annual average value <75%.

**Maximum current 3x80A. Standby loss 0.5 watt per path only.**

Modulair device for DIN-EN 60715 TH35 rail mounting in distribution cabinets with IP51 protection class.

4 modules = 70mm wide and 58mm deep.

Accuracy class B (1%). With SO interface as standard.

It measures active energy by means of the current between input and output. The internal power consumption of 0.5 watt active power per path is neither metered nor indicated.

1, 2 or 3 phase conductors with max. currents up to 80A can be connected. The inrush current is 40mA.

The N terminal must always be connected.

**The 7 segment LC display is also legible twice within a period of 2 weeks without power supply.**

Power consumption is shown by a bar flashing at a rate of 100 times per kWh.

**Designed as standard for using as double-tariff meter:** Switch over to a second tariff by applying 230V to terminals E1/E2.

On the right next to the display are the keys MODE and SELECT. Press them to scroll through the menu. First the background lightingswitches on. The display then shows the total active energy per tariff, the active energy of the resettable memory RS1 or RS2 as well as the instantaneous values of consumption, voltage and current per phase.

**Error message (false)**

When the phase conductor is missing or the current direction is wrong 'false' and the corresponding phase conductor are indicated on the display.

**Typical connection:**

4-wire-connection 3x230/400V

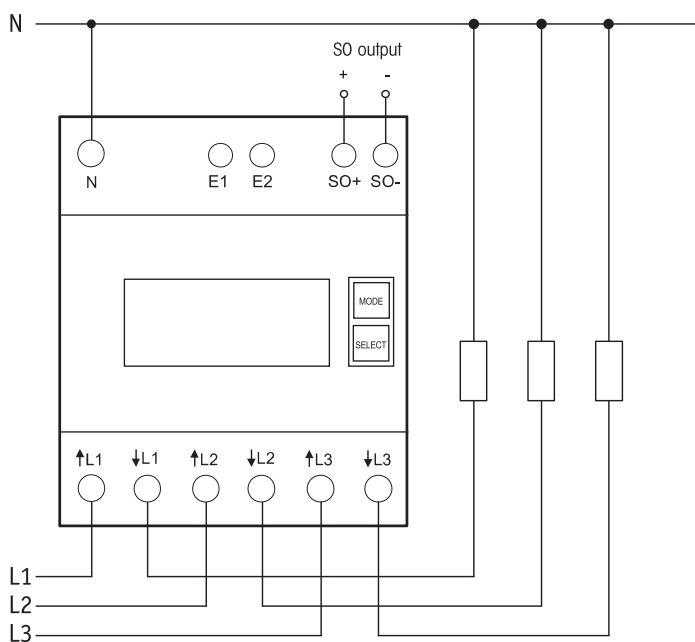

**Technical data**

Rated voltage, extended range	3x230/400V, 50Hz, -20%/+15%
Reference current $I_{ref}$ (Limiting current $I_{max}$ )	3x10 (80)A
Internal consumption active power	0.5W per path
Display	LC display 7 digits, therefrom 1 or 2 digits after the decimal point
Accuracy class $\pm 1\%$	B
Inrush current according to accuracy class B	40mA
Operating temperature	-25/+55°C
Interface	Pulse interface SO according to DIN EN 62053-31, potential free by opto-coupler, max. 30V DC/20mA and min. 5V DC, impedance 100 ohms, pulse length 30ms, 1000 Imp./kWh
Terminal cover sealable	Terminal cover claps
Protection degree	IP50 for mounting in distribution cabinets with protection class IP51
Maximum conductor cross section <sup>1)</sup>	L terminals 25 mm <sup>2</sup> , N terminals 16 mm <sup>2</sup> , SO terminals and tariff terminals 6 mm <sup>2</sup>
Recommended torque <sup>2)</sup>	L terminals 2,0Nm (max. 2,5Nm) N terminals 1,5Nm (max. 2,0Nm) SO terminals and tariff terminals 0,8Nm (max. 1,2Nm)
EC type examination certificate	0120/SGS0204
Mechanical environmental conditions	class M1
Electromagnetic environmental conditions	class E2

<sup>1)</sup> The carrying capacity of cables and wires is defined in DIN VDE 0298-4.

<sup>2)</sup> The torques for screw terminals are mentioned in DIN EN 60999-1.

**To avoid damages at the energy meter, the recommended torque values for each terminal must not be exceeded!**

**Menu guidance**

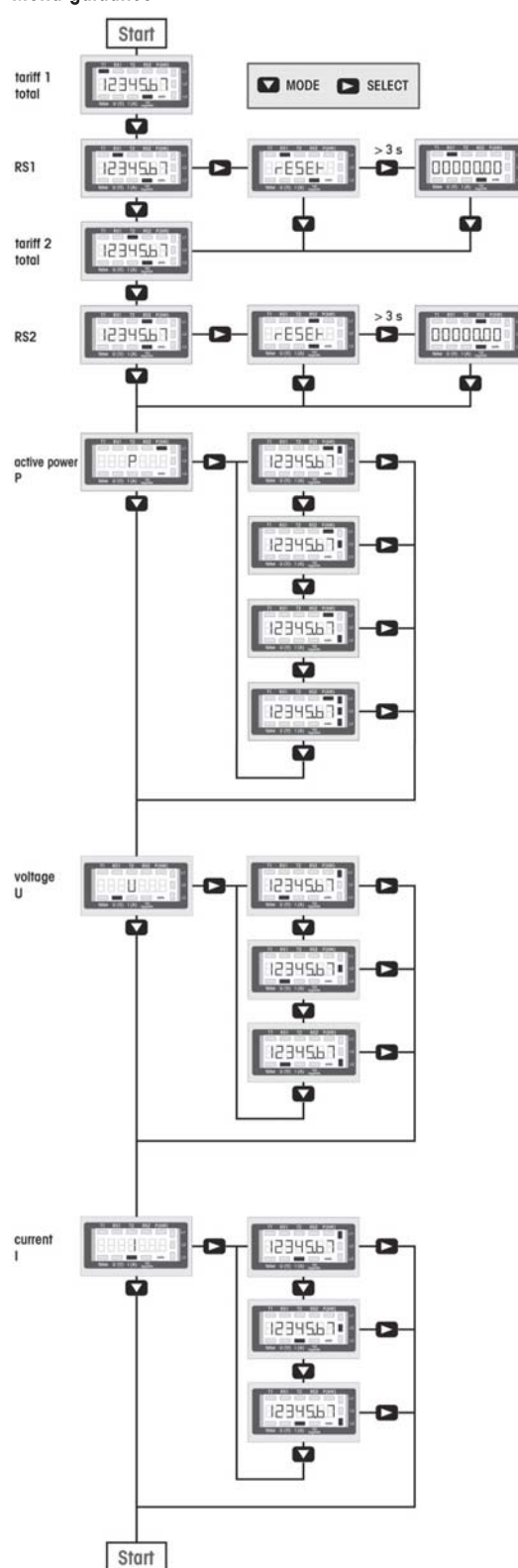

**EC DECLARATION OF CONFORMITY**

File name	FQKZ054-CR
Product	Three-phase energy meter with MID approval
Type designation	DSZ12D-3x80A
EC-type examination certificate	0120/SGS0204
The manufacturer herewith declares, on his own responsibility that the designated products which this certificate refers to, are in accordance with the following harmonized standards or normative documents as well as with the following Directives of the European Parliament and of the Council ( relevant version ):	
DIN EN 50470	parts 1 and 3 : May 2007 ( electronic meters )
2014 / 32 / EU	measuring instruments
2014 / 30 / EU	electromagnetic compatibility
2011 / 65 / EU	restriction of the use of certain hazardous substances ( RoHS Directive )
The designated products are placed on the market by ChuangRen Guangming Dist. Shenzhen China	
Notified body	SGS United Kingdom Limited , No. 0120 Unit 202B Worle Parkway, Weston-super-Mare, ES22 6WA. UK
Manufacturer	Shenzhen Chuangren Technology Co. Ltd. Building 33, No.3 Industrial Area, Mashantou, Gongming Street, New Guangming District, Shenzhen City, Guangdong Province, 518106, China
Place, Date	Shenzhen, 25 May 2016
Signature	
This declaration proves the compliance with the above-mentioned EC Directives but it does not include any assurance of properties. Security advices of the provided product information have to be noticed.	

ChuangRen Technology Co.,Ltd  
Guangming Dist. Shenzhen China  
+86 755 27110050  
www.chuang-ren.com